

ARCspectro HT-2D

ARCOptix
Switzerland

DATA SHEET



Ultra - Compact High - Throughput Fourier Transform Spectrometer

The ARCspectro HT-2D is an ultra compact stationary Fourier transform spectrometer. Based on polarization optics it provides an extremely high sensitivity and is ideal for measurements of low light and diffusing sources (diffuse reflection and turbid media). Its unique design permits to collect light over a large angles and it has an high entrance surface of several millimeters. The operation principle prevents from problems like drift or dark noise which allows high contrasts at single shot measurements. Thanks to its 2D camera it averages over 1000 measurements in one shot!

It can be used in extremely simple optical setups, no need for focusing optics. The user can directly illuminate the entrance opening with the light to be spectrally analyzed or can bring the light to the system with fiber bundles.

Typical characteristics of the HT series are

- **Ultra High throughput (100x more than a grating spectrometer)**
- **Large spectral range: 400nm-1100nm**
- **Very low dark noise 0.02 counts (1024 lines averaging)**
- **Simple optical setup (no need for extra optics)**
- **Hardware and software trigger**
- **No drift**
- **Very short integration times (0.05ms)**
- **Variable Gain**
- **No moving parts**
- **Metallic anodized housing with useful fixation treads**

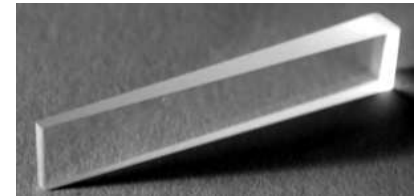

FEATURES & BENEFITS

Good resolution and High throughput are combined in Fourier transform spectroscopy because resolution is limited by the maximum optical path difference and not by the entrance slit. The **entrance aperture** is several millimeters large.

The heart of the HT 2D is made of materials that are transparent over a **large spectral range** and the sensitivity is only limited by the detector. Also a Fourier Transform Spectrometer does not need second order rejection filters.

The **external and software trigger** allow to use the instrument for industrial application where precise control is necessary.

A **monolithic bloc design** makes the HT 2D insensitive to external conditions and **robust**.

Simple optical setup integration is possible because there is no need for injection or fiber optics.

ARCspectro HT-2D

ARCOptix
Switzerland

DATA SHEET

ARCspectro HT 2D specification overview:

Spectral range	400 nm – 1100 nm
Signal-to-Noise (single measurement full detector dynamic used, Ratio between the peak value and bottom Std. Dev. value of HeNe Spectrum)	3000 :1 (Multiplex advantage)
Detector type	CMOS Silicon 2D detector array 1280x1024 Pixels
Spectral Resolution (FWHM)	
400 nm	1.7 nm
700 nm	5 nm
1000 nm	10 nm
Dark Noise standard deviation (Low value due to averaging over the 1024 lines of 2D detector!)	0.02 Count
Dynamic range (full dynamic/dark noise)	13'000
Relative Wavelength Accuracy and repeatability	< 0.01 nm
Absolute Wavelength Accuracy	< 0.5 nm
Operating Temperature	10°C – 50°C
Readout time (full 2D frame)	40 ms
Integration time	0.05 ms – 750 ms
Operating Voltage	5 V (USB powered)
Light guide core diameter (optional)	4 mm
Entrance aperture	4 mm (Diam.)
Numerical Aperture (internally)	NA = 0.2
Communication Interface	USB 2.0
Software Interface	Windows XP
Product Dimensions (including electronics)	60 mm x 60 mm x 80 mm
Product Weight	300 g
Power Consumption	< 1 W
Wavelength temperature drift	< 0.001nm/°C

Técnicas Asociadas de Instrumentación, S.L.
For more information about ARCOptix, visit <http://www.taisl.com/>

The ARCSpectro HT 2D is highly modular systems and ready for custom spectroscopy.

Light can be brought to the spectrometer via a **4mm diameter light guide**



Data transfer and power supply via **USB port**. **External trigger and software trigger** and very short shutter times.



Software Module for Windows XP, DLL Available

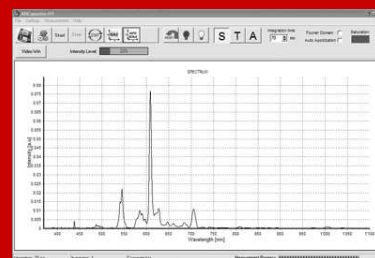

ARCspectro HT-2D

ARCOptix
Switzerland

DATA SHEET



The ARCspectro HT-2D is easy to use: No complicated optical setup, no fibers and no lenses. Just put what you want to measure in front of the entrance aperture and start your measurement.

The ARCspectro HT 2D is able to work over wide dynamic range not only thanks to its variable integration time but also thanks to a **variable amplification gain** that can be set by the user.

Thanks to the averaging of 1024 spectra per single measurement due to its 2D camera, the ARCspectro HT 2D **has a very low dark noise of only 0.02 counts**. That has to be compared with traditional grating spectrometers that have dark noises between 3 and 40 counts!

Due to its functional principle (Fourier spectroscopy), the ARCspectro HT 2D **can measure relative peak positions with much higher accuracy** and has practically **no drift**.

The ARCspectro HT 2D has useful M4 and M6 threads on the front and the side for fixation in a setup.

Mechanical Drawings:

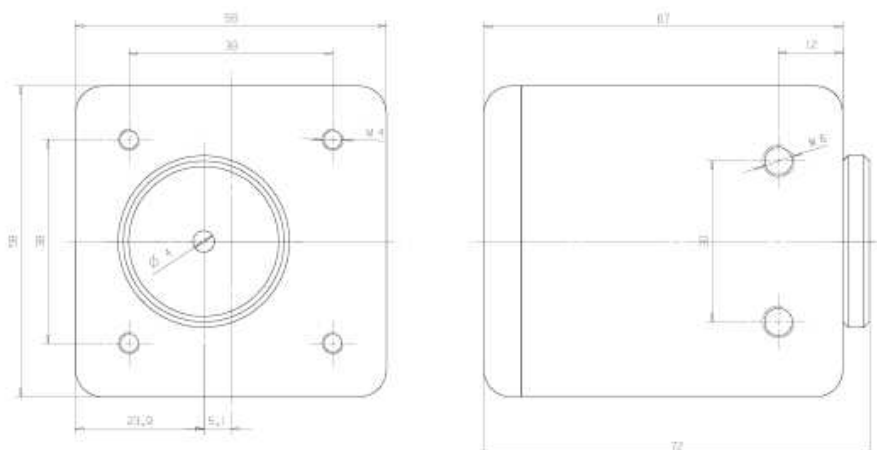

Applications

- Diffuse reflection spectroscopy
- Turbid media transmission spectroscopy
- Fluorescence spectroscopy
- Precise peak position (or wavelength determination)
- Colorimetry

For additional information please contact:

Técnicas Asociadas de Instrumentación, S.L.

Tel. +34 (91) 3555803

Fax +34 (91) 3555803

info@taisl.com

<http://www.taisl.com/>.

