

ARCsmev

AR©ptix
Switzerland

DATA SHEET



Patent pending

Low-Cost Laser Interferometer for In-Plane Displacement Measurement



ARCsmev (Self-Mixing Effect Velocimeter) patented technology offers new perspectives in the measurement of in-plane displacements. With comparable performances than standard Laser Doppler Velocimeter, the low cost and compactness of the device enlarge the scope of utilization of non-contact displacement measurement.

This unique method use a laser diode driven in a quasi single mode. Mode competition is influenced by the light reflected from the target under measurement. Observing the variation of the emitted mode gives information of displacement. The scheme offers robust signals regarding the surface quality and reflectivity.

- . High precision
- . Compact
- . Robust regarding surface quality (rough to quasi polished)
- . Attractive prices

Applications

- .Watch Industry
- .Microtechniques
- .Flow control in production

For additional information please contact:

TÉCNICAS ASOCIADAS DE INSTRUMENTACIÓN, S.L.
CL. María Teresa, 17 – 3C / 28028 Madrid, Spain
Tel. +34 (91) 3555803 Fax +34 (91) 3555803
info@taisl.com <http://www.taisl.com/>

FEATURES & BENEFITS

Self-Mixing Effect using quasi single mode operation of a laser diode allows a robust and compact measurement unit.

Surface insensitive. The signal quality does not depend on the reflected intensity. The low threshold intensity needed to get a signal allows its use on quasi polished surfaces.

High Precision is achieved by processing the data with a phase discrimination algorithm. Displacement with a sub-micron resolution can be achieved.

High speed data acquisition and transmission is achieved using a dedicated electronics with the USB 2.0 bus.

ARCsmev

AR@ptix
Switzerland

DATA SHEET

General specifications

Measurement speed range	10 - 2000 mm/s
Displacement resolution	< 1 μm
Working distance	40 mm
Laser wavelength	670 nm
Laser output power	< 5 mW
Communication	USB 2.0
Power supply	5V, USB powered

Outlines

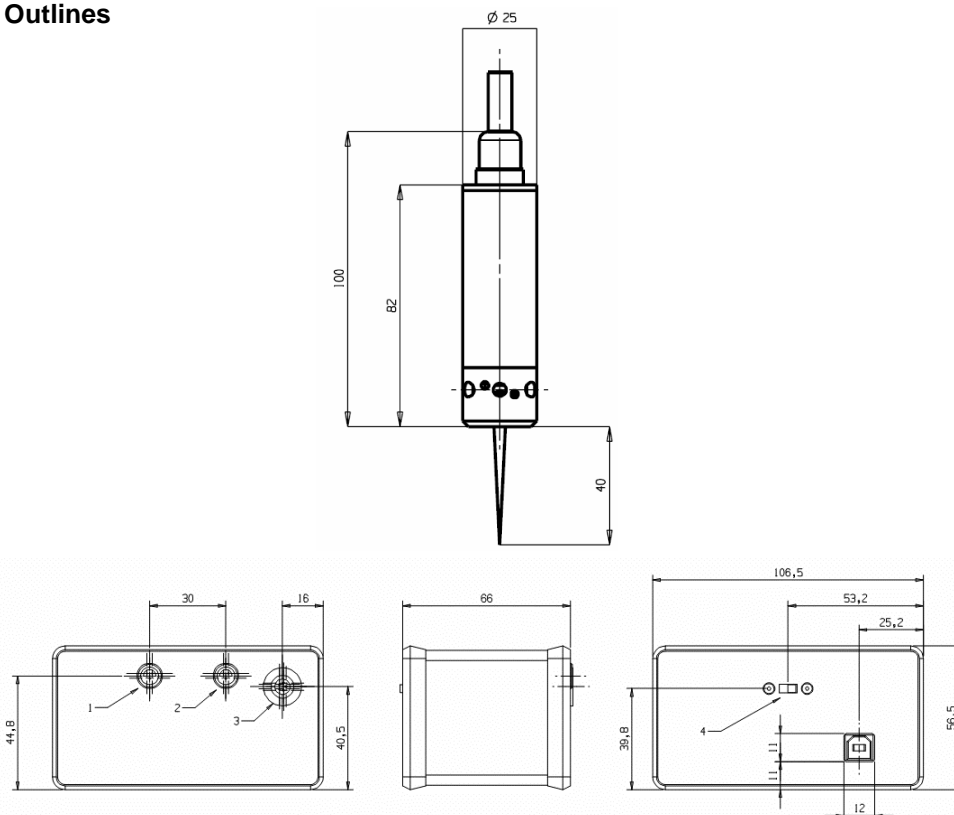

Watch industry

Witschi Electronic SA, leader in measurement equipment for the watch industry, is the supplier of the sensor for the watch industry. The device is implemented in measurement system combining optic and acoustic measurement. New and unique information are obtained, useful to the high quality watch maker.

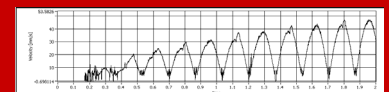

Vitesse du balancier

Erreur de déplacement par rapport à un déplacement sinusoïdal d'une alternance (4ème depuis la fin) (en rouge, bruit des chocs de l'ancre avec le balancier)

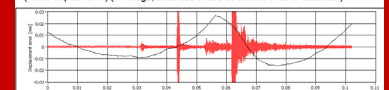

welcome@witschi.com

Técnicas Asociadas de Instrumentación, S.L.
Para más información visite <http://www.taisl.com/>